

How to Measure for Window Treatments

Use a steel tape measure.

- (1) Window width
- (2) Window length
- (3) Left extension
- (4) Right extension
- (5) Distance above
- (6) Distance below

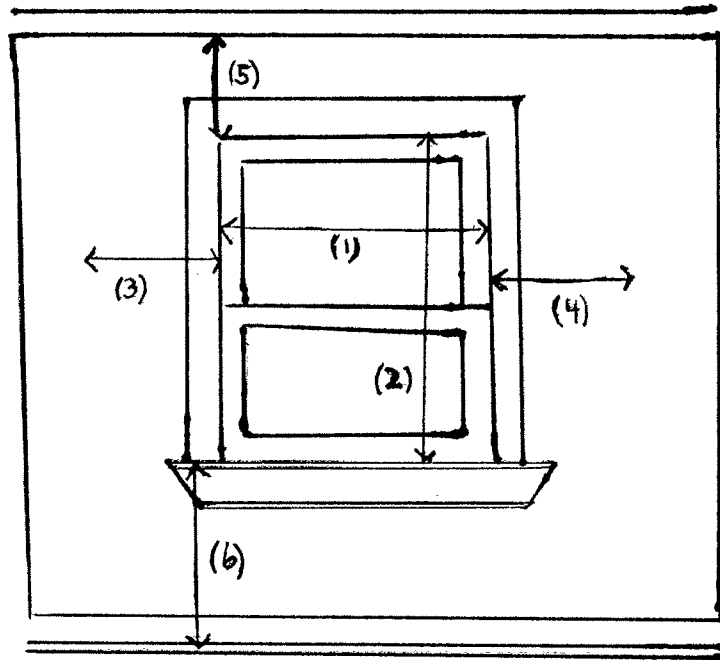

Decide if the treatment will be mounted inside the window or if it will hang outside the opening.

Mounted inside: you only need to measure the width of the opening (1) and the length (2).

Hang outside: determine width (1) and length (2) and also area to be covered to the left (3) and right (4) of the opening and from the top (5) and bottom (6).

Shades usually extend $\frac{1}{2}$ inch beyond the trim board on each side or 2 inches beyond the window opening if there is no trim.

The top of window treatments is usually even with the top of the trim board. Window treatments can also begin just below the ceiling, at the bottom of crown molding, or halfway between the ceiling and window opening.

Valences usually begin 8 inches above the opening.

Window treatments usually end in line with either the window or the floor. Floor-length treatments should end $\frac{1}{2}$ inch short of the floor, unless you live in a high humidity area where they should end 1 inch above the floor.

Puddling is the name for the designer detail where draperies and curtains have an additional 10-12 inches of fabric added to the finished floor length.